

# Lessons on Combining Topology and Geography — Visual Analytics for Electrical Outage Management

Alexander Jäger<sup>1</sup>, Sebastian Mittelstädt<sup>1</sup>, Daniela Oelke<sup>2</sup>, Sonja Sander<sup>2</sup>, Axel Platz<sup>2</sup>, Gies Bouwman<sup>3</sup> and Daniel Keim<sup>1</sup>

<sup>1</sup>University of Konstanz, Germany

<sup>2</sup>Siemens AG, Germany

<sup>3</sup>Alliander, The Netherlands

---

## Abstract

*Outage management in electrical networks is a complex task for operators and requires comprehensive overviews of the topology. At the same time valuable information for detecting the root cause may have geographical context such as digging activities or falling trees. Consequently, vendors of state-of-the-art SCADA systems started to integrate this valuable information source as well. However, in today's systems both views are separated, requiring operators to mentally connect the geographical and topological information. The wish of operators is to provide a comprehensive combination of both spaces in a single view. However, how to project geographical elements into the topology to support the workflow of real operators is yet unclear. In this paper, we present a design study for an interactive visualization system that provides a comprehensive overview for power grid operators. It provides full coverage of both spaces in order to measure how real operators make use of the geographical information. It bypasses the projection problem by interactive brushing-and-linking to support associative analysis. We extracted the mental-model of domain experts in real use cases and found a general bias source in sequential analysis of two spaces. We contribute our problem and task abstraction, lessons learned, and implications for future research.*

---

## 1. Motivation

Today's distribution grid operators face significant challenges: The integration of renewable energy sources turns existing operation paradigms upside down and brings the existing infrastructure to its limits. The likelihood of outages increases. Besides supervisory control information such as alarm messages and equipment states, operators need to analyze different geographic data sources like trouble calls, smart meter signals and weather information. They require comprehensive views on data and effective means for data analytics.

State-of-the-Art control center SCADA (supervisory control and data acquisition) systems provide topological views of the electrical grid. Like a schematic map for public transportation, these simplified views are optimized to reveal an overview of the network topology. Vendors outside the SCADA world offer visualization software that is separate from the SCADA system. Typical views show satellite images with layers of 2D or 3D bar charts [OMWJ05]. Consequently, SCADA vendors have started to integrate geographical views additionally to topological views. However, the geographical view is mainly focused on displaying information while the topological view is the main tool for taking actions. There-

fore, operators are lacking awareness of the geographical situation while taking actions in the power grid topology.

The combination of topological and geographical data is a general problem for visualization research: Distances may significantly differ in topology and geography. Thereby, connections or elements in one space have to be disrupted/distorted or redundantly visualized if they are combined in one visualization. This general optimization problem can be solved by minimizing distance distortions, redundancy, disruption of intra-space and inter-space relations [BBDZ08]. The operator's analysis tasks require an accurate projection of specific information within the topology and geography, which cannot be effectively provided by global projections. Therefore, projecting all geographical elements and their relations into a topology will inefficiently result in an inoperable (overloaded) trade-off visualization. For effective outage management, smart filtering and projections must support the analysis task of the user. However, it is unclear *when* and which information is required to support the workflows of real operators.

In this paper, we present a design study of an interactive visualization system to extract the mental model and workflows of power grid operators to combine the information of two

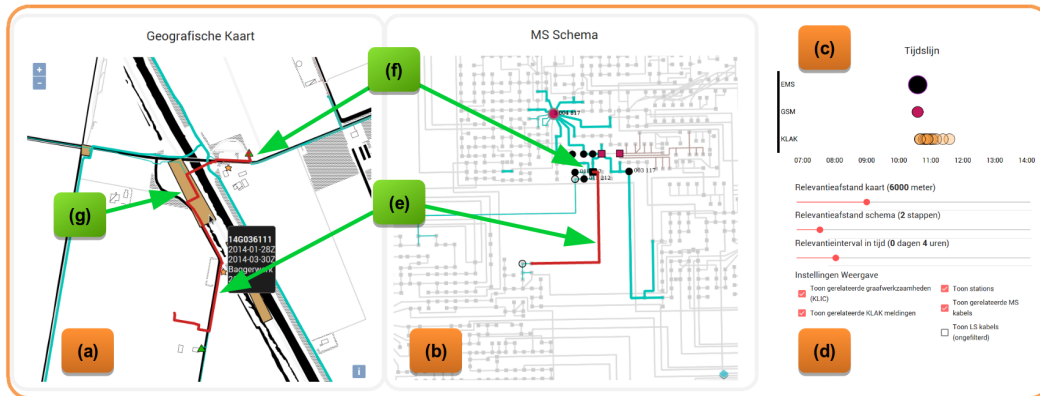

**Figure 1:** The system's main components: a geography view (a), a topology view (b), a time-line (c) and smart filtering (d) are used in combination to identify the cause of an outage (e.g. earthworks(g)). Views are linked (e,f) and relevant parts of the network are extracted and highlighted according to filtering rules and all available data (such as customer trouble calls).

spaces. Our solution is a juxtaposed visualization providing comprehensive overviews of the power grid's topology and its geographic context, which enables associative analysis by interactive brushing-and-linking. We selected this approach because of the full but separated coverage of both spaces. We extend established techniques in the target domain and, thereby, reduce learning barriers as well as training requirements of domain experts. This does not limit the available data in the analysis, is simple to use, and enables capturing *when* and *which* geographical information is required. We claim the following contributions: 1) problem and task abstraction for outage management; 2) the workflow of real domain experts when combining two spaces based on our pair analytics study [AHKGF11]; 3) identified challenges and implications for future research.

## 2. Design Study Setup & Problem Abstraction

**Scenario.** Components of today's power distribution grids are typically not telemetered. The operator does not know the equipment state unless a crew arrives on site. Consequently, detecting the root cause of a service disruption in such networks is a complex task that requires intensive manual analysis and a work force on site. A fast response and restoration of power is critical, due to legal and financial requirements.

**Topological Data.** Our data originates from real world power outages occurring in a large European medium voltage power distribution grid. The main components of this network are local secondary substations (customer supply), main substations (connection to the high-voltage grid), and cables connecting the stations and households. Central stations can report the failure of a larger sections of the network (often affecting thousands of customers). Within these sections, some stations are able to report their status and potential problems.

**Geospatial Data.** Typically, emergency analysis is done via the *topology* of the network. Additional meta information about cables, stations, customer trouble calls, and legal

mandatory earthwork notifications are available. This *geospatial* data is important for root cause analysis since common causes for outages are, for example, digging activities that cut cables or falling trees.

**Design Study Setup.** We performed our design study involving the liaison concept [SMKS15]. Thereby, we split the project members into three domain experts *DE* (senior power grid operators, two with additional scientific background), four visualization experts *VIS*, and two liaisons (*LI*: system engineer for an energy provider and research consultant for visual analysis, *L2*: product manager for power grid management systems). *L1* provided the data and assisted *VIS* in the task and problem abstraction, as well as provided the data and assisted as multilingual translator (English - Dutch, visualization - energy domain). Further, his obligation was to ensure that the visual designs satisfy the needs of *DE*. *L2* advised the design concepts from the state-of-the-art perspective. *DE* were interviewed in their native language by *L1* to specify analysis tasks and participated in the pair analytics study. *VIS* abstracted the tasks, developed visualization concepts, and performed the pair analytics study.

**Problem Abstraction.** For the abstraction of analysis tasks, we apply the task typology of [BM13]. The two main goals of the operators are the identification of potential root causes for outages and then the restoration of the network. The latter is beyond the scope of this paper since this requires communication and guidance with technicians in the field. We focus on the first main analysis goal, which is to *discover* relevant elements in *undirected graphs* (power grid topology) that are related to elements and events in their *spatial (geographical) context*. The tasks within this goal comprise:

- T1** Identify the parts of the network affected by the outage:  
The analyst *localizes* the edges and nodes of the graph that are connected and share the property of failure.
- T2** Estimate the size and external information of the outage:  
The analyst must *explore* the failed graph elements in their

spatial context to *identify* and relate (*compare*) external information to the topology.

**T3** Filter relevant candidates for root causes: The analyst *explores* the elements identified in T1 and T2 to *identify* top-candidates for root-causes.

**T4** Create restore plan: The analyst *looks-up* and *relates* the top-candidates to create strategies for the field-technician to begin with the restoration.

### 3. Related Work

Using visual analytics to maintain situational awareness in the context of critical infrastructure is an active topic of research. Kohlhammer et al. [KMH09] present systems that have been developed accordingly and how they are applied to relevant application use cases. Mittelstädt et al. [MWE\*15] use multiple views within a control room setup to combine different infrastructure networks with time critical reports from crisis response teams. Visualizing the status and change behavior of distribution networks has been the focus of industrial and scientific research in the past [SE15, KSO02, KDW03, SMDK13]. Recognizing the importance of different views of a network, Cornélusse et al. [CLGE15] propose the use of graph matching algorithms to combine geographic and topological databases. Combining these databases in one view has been the topic of several papers in the past. Different approaches and ideas can be found in a survey by Steiger et al. [SBMK14]. Of special interest is the work by Böttger et al. [BBDZ08], which automatically distorts a geographic map and fits it to a metro topology.

### 4. System

**Visual Analytics Components.** The final application is shown in Fig. 1. Its main components are the central map views. On the left, we show the geography view (Fig. 1 (a)) of the network, which includes exact GIS based equipment coordinates and paths. On the right, a state-of-the-art topology view (logically optimized) can be seen (Fig. 1 (b)). It is important to note that neither view is redundant and each holds critical information according to domain experts [T1,T2,T4].

To support associative analysis [T2], interactions between those views are provided by the principle of linking and brushing [Kei02] (Fig. 1 (e) and (f)). In particular, the user can gather information about a network element in either view by panning and zooming the view and using the on-demand mouse over information for identification. By clicking the element, it is focused and highlighted in all visual elements of the system. Both views will visually emphasize the selection and automatically zoom and navigate to it. Further, hovering actions can then be used to gather the remaining informations about the element [T2,T3]. This decision was made in order to establish a baseline system, which can be used to capture workflows and decision making processes of real users.

Additional views such as an interactive time-line (Fig. 1 (c)) and a listing of relevant entities in tabular form are

presented to further assist the analysis. They take into account the behavior of events happening in real time where sensor messages and customer trouble calls do not arrive instantly. The design goal of this system is to quickly gather comprehensive information about equipment, to determine its location and function within the network's geographical and topological structure, and to draw conclusions about potential fault sources [T2], such as earthworks cutting a cable in Fig. 1 (g).

**Smart filtering.** Since most parts of the network are not relevant to the user in root cause detection, we provide smart filtering. Combining direct error messages (e.g., from central stations or remote sensors) with derived data about affected network components (e.g., by tracing the topological origin of trouble calls within the network) we are able to focus attention and visually highlight critical parts of the infrastructure. Only if a component is close to the central station (from which the outage was reported in the geographical, topological or temporal dimension, see Fig. 1 (c)), it is considered for highlighting. The user can influence the filtering process by setting upper limits on the selection of events (Fig. 1 (d)). We expect to see use of this feature once the real dimensions of the outage emerge through analysis [T3].

### 5. Evaluation

#### 5.1. Study Procedure.

Our pair analytics study consisted of three different parts: (1) *VIS* presented the system to all users; (2) *DE* executed controlled basic tasks for training to perform *T1-T4* (separately); (3) a set of real use cases to discover the root cause of outages. This was followed by a group discussion to capture first insights. Parts (2) and (3) were video recorded.

In part (2), the basic tasks comprised, e.g., to locate well known locations in the geographic map and to navigate through the topological network. Next a series of questions such as 'Locate a station on the geographic and on the topological map' (*T1, T2*) or 'Filter all elements with distance *X* to station *Y*' (*T3*) required the interactive use of all components of the tool. The third part (3) of the study consisted of a predetermined set (by *L1*) of real use case scenarios. In each, the user was presented with the initial event of a power outage reported in a central station. They were then asked to localize a network component (e.g. cable, transformer station) or at least a general area where the outage probably occurred. The true root cause was only known by *L1* and *VIS*.

*VIS* led *DE* through (2) who operated the system themselves. *VIS* gave advice in (2) on *DE*'s requests or in case of clear misunderstandings, while *L1* made sure to close the communication gap. In (3), *VIS* and *L1* presented the outage event and then only acted as interested analysis partner without giving any advice on how to perform tasks. *VIS* asked questions like 'Why do you think this is interesting?' and 'What are the reasons you did...?' to capture study insights.

## 5.2. Results

In the discussion round after the study, we captured the first ‘group’ insights that are analyzed in the following:

- I1 Training tasks could be completed with no major issues.
- I2 All experts identified the true root causes in the use cases.
- I3 The smart filtering concept is not useful for the task.
- I4 The focus of the users is on the topology view.
- I5 Users use the topology view and the geography view sequentially rather than simultaneously.

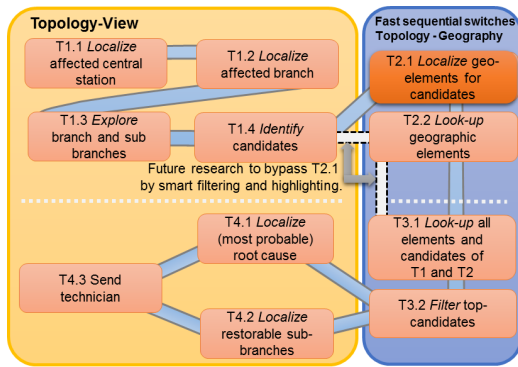

**Figure 2:** Workflow of domain experts to resolve the outage in our experiments. All experts focused on the topology and only switched to geography view for confirming hypothesis (with the risk of confirmation bias in T2.1).

FA extracted the workflow of DE illustrated in Fig. 2. In summary, DE performed most tasks (esp. T1 and T4) predominantly with the topology view. Although, T2 can be solved solely with the geography view, DE rather performed fast switches between the projections if they felt geographic information was required to support their task and hypothesis. This is confirmed with our group insights I4 and I5.

## 5.3. Findings, Lessons Learned, and Open Challenges

From the study results we were able to draw conclusions and implications to support the workflow of our experts.

**Revision of Juxtaposed Solution.** I1 and I2 indicate that DE could solve the tasks with our juxtaposed solution. However, the geography view was never in the focus of the analysis (I4,I5). Therefore, we see a clear need to advance to current state-of-the-art and to support the workflow of DE by, e.g., an one-view solution with topology-focus and projected geographic elements.

**Revision of Smart Filtering: ‘When to provide geo-data’.** I3 indicates failure of our smart filtering concept. We expected DE to generate candidates in both views (independently) by applying an automatic filtering step (with high recall) and then perform manual analysis (high precision). As indicated in Fig. 2, however, DE generated candidates by a detailed analysis of the topology (T1.1-T1.4) and then *localized* associated elements in the geographic view (T2.1). An automatic filtering is, therefore, not necessary because their

mental-model already provides optimized concrete analysis steps for filtering based on their experience.

The desired future one-view solutions will, however, require a filtering with a parameterizable detection of relevant elements and a parameterizable projection, since the analyst must be able to specify which elements should be projected from geography to topology and which characteristics (coordinates, connections, relationships) should be preserved. The future system should track interactions of the user in the topology (T1.1-T1.4), determine the parameters of modeling and projection, and provide the available relevant geographical elements. This approach bypasses T2.1, which is more in-line with the current workflow of DE, and can also help to mitigate the *confirmation bias* described below.

**Danger of Confirmation Bias.** This bias originates from ignoring information that does not agree with the user’s hypothesis [KT72]. Phillips et al. [PPP14] present that users reduce their likelihood to explore data because they reduce the perceived usefulness of information that does not reinforce their current premise [SSK\*16]. In contrary to our task abstraction, DE did not make use of the exploratory nature in T2 and T3 (Fig. 2) since they rather associated geographic information when this was required to validate their candidates identified in the topology (at T2.1). This finding is also valid for the current state-of-the-art since the source of the bias is the sequential usage of the ‘external’ geographic information in an extra view.

**Future Work.** There is a chance to influence reasoning processes if the operator’s attention is dragged towards possible candidates outside his/her expectations to mitigate this bias. Since the users in our domain have extensive experience and their mental-model to filter irrelevant information efficiently, smart filtering could be configured to select relevant geographic elements with high recall that are projected into the topology view. This would enable an associative analysis and mitigation of biases in one view. However, such solutions increase the complexity for the visualization and the analysis. We argue that this is an open research problem for visual analytics in this target domain, which clearly requires careful and reasonable research. It will be interesting to find different ways to mitigate biases in general and a trade-off between a high recall of meaningful elements and avoiding information overload in one-view solutions for this target application.

## 6. Conclusions

In this paper, we presented the problem and task abstraction in the power grid domain for outage management. Our interactive comprehensive visualization system for combining topological and geographic information supported us in the extraction of the mental model and workflow of our domain experts. We identified challenges for smart filtering concepts and for combined one-view solutions that have to mitigate the identified cognitive biases in this target domain. Future research may follow up these insights and abstractions to create solutions that satisfy the needs of the end users.

## References

- [AHKGF11] ARIAS-HERNANDEZ R., KAASTRA L. T., GREEN T. M., FISHER B.: Pair analytics: Capturing reasoning processes in collaborative visual analytics. In *2011 44th Hawaii International Conference on System Sciences (HICSS)* (2011), IEEE, pp. 1–10. 2
- [BBDZ08] BOTTFGER J., BRANDES U., DEUSSEN O., ZIEZOLD H.: Map warping for the annotation of metro maps. *Computer Graphics and Applications, IEEE* 28, 5 (2008), 56–65. 1, 3
- [BM13] BREHMER M., MUNZNER T.: A multi-level typology of abstract visualization tasks. *IEEE Transactions on Visualization and Computer Graphics* 19, 12 (2013), 2376–2385. 2
- [CLGE15] CORNÉLUSSE B., LEROUX A., GLAVIC M., ERNST D.: Graph matching for reconciling scada and gis of a distribution network. In *Proceedings of the International Conference on Electricity Distribution, CIRED 2015* (2015). 3
- [KDW03] KLUMP R., DOOLEY G., WU W.: Displaying aggregate data, interrelated quantities, and data trends in electric power systems. In *Proceedings of the 36th Annual Hawaii International Conference on System Sciences*. (2003), IEEE, pp. 10–pp. 3
- [Kei02] KEIM D. A.: Information visualization and visual data mining. *IEEE Transactions on Visualization and Computer Graphics* 8, 1 (2002), 1–8. 3
- [KMH09] KOHLHAMMER J., MAY T., HOFFMANN M.: Visual analytics for the strategic decision making process. In *GeoSpatial Visual Analytics*. Springer, 2009, pp. 299–310. 3
- [KSO02] KLUMP R., SCHOOLEY D., OVERBYE T.: An advanced visualization platform for real-time power system operations. In *Proc. of the 14th Power Systems Computation Conference* (2002), vol. 2. 3
- [KT72] KAHNEMAN D., TVERSKY A.: Subjective probability: A judgment of representativeness. *Cognitive psychology* 3, 3 (1972), 430–454. 4
- [MWE\*15] MITTELSTÄDT S., WANG X., EAGLIN T., THOM D., KEIM D., TOLONE W., RIBARSKY W.: An integrated in-situ approach to impacts from natural disasters on critical infrastructures. In *48th Hawaii International Conference on System Sciences (HICSS)* (2015), IEEE, pp. 1118–1127. 3
- [OMWJ05] OVERBYE T. J., MELIPOULOS A. P., WIEGMANN D. A., J. C. G.: Visualization of power systems and components, final report. *IEEE Transactions on Visualization and Computer Graphics* 05, 65 (2005), 1–83. 1
- [PPP14] PHILLIPS B., PRYBUTOK V. R., PEAK D. A.: Decision confidence, information usefulness, and information seeking intention in the presence of disconfirming information. *Informing Science: the International Journal of an Emerging Transdiscipline* 17 (2014), 1–25. 4
- [SBMK14] STEIGER M., BERNARD J., MAY T., KOHLHAMMER J.: A survey of direction-preserving layout strategies. In *Proceedings of the 30th Spring Conference on Computer Graphics* (2014), ACM, pp. 21–28. 3
- [SE15] SANDER S., EICHLER R.: 2d and 3d visualization strategies for distribution management. *23rd International Conference on Electricity Distribution* (2015). 3
- [SMDK13] STEIGER M., MAY T., DAVEY J., KOHLHAMMER J.: Smart grid monitoring through visual analysis. In *Innovative Smart Grid Technologies Europe (ISGT EUROPE), 2013 4th IEEE/PES* (2013), IEEE, pp. 1–5. 3
- [SMKS15] SIMON S., MITTELSTÄDT S., KEIM D. A., SEDLMAIR M.: Bridging the gap of domain and visualization experts with a Liaison. In *Eurographics Conference on Visualization (EuroVis) - Short Papers* (2015), Bertini E., Kennedy J., Puppo E., (Eds.), vol. 2015, The Eurographics Association. doi:10.2312/eurovisshort.20151137. 2
- [SSK\*16] SACHA D., SENARATNE H., KWON B. C., ELLIS G., KEIM D. A.: The role of uncertainty, awareness, and trust in visual analytics. *IEEE Transactions on Visualization and Computer Graphics* 22, 1 (2016), 240–249. 4